

# FT- 5719 SMALL RANGE

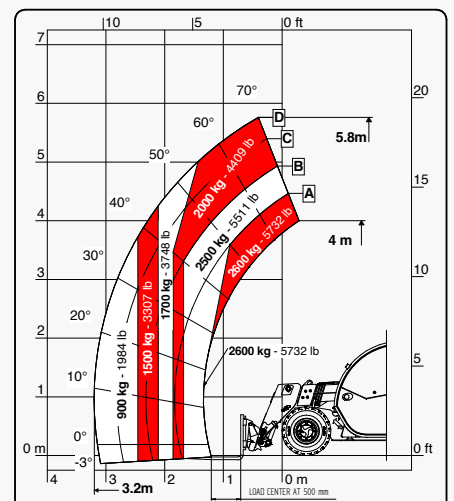

It brings to the attention of all potential customers, all recipients, and to the maximum extent possible, external interlocutors, that Faresin Industries S.p.A. adopts a general Disclaimer regarding the description of the technical and functional characteristics of its machineries, as well as the manner of their use, also with regard to their safety. The Disclaimer must be understood as having a general scope, and therefore Faresin Industries s.p.a. invites to know it, also by accessing the website: [www.faresindustries.com](http://www.faresindustries.com)

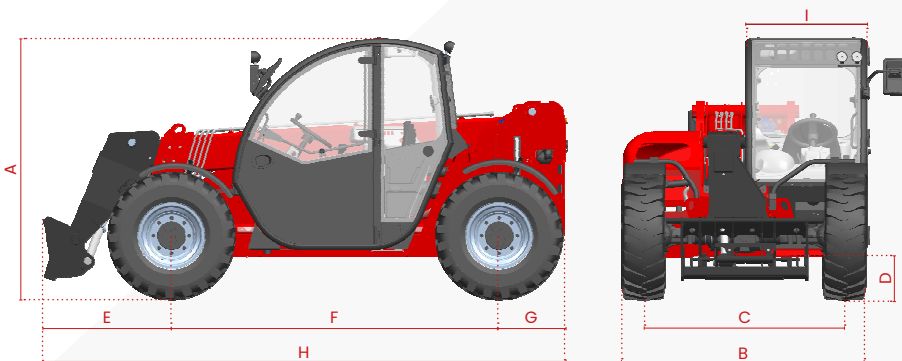

**FARESIN.COM**



# FT-5719 SMALL RANGE

## TECHNICAL FEATURES

MODELS		FT-5719
<b>DIMENSIONS</b>		
[A] Height	ft	6.3
[B] Width	ft	6.2
[C] Gauge	ft	5
[D] Ground clearance	ft	8.6
[E] Front overhang	ft	3.2
[F] Pitch	ft	8.2
[G] Rear overhang	ft	1.7
[H] Length without tow hitch	ft	13.2
[I] Cabin width	ft	3.1
<b>WEIGHT</b>		
Classic 52	lbs	10,361
<b>DETAILS</b>		
Number of extracting sections	nr	1
Max capacity	lbs	5,732
Max lifting height	ft	19.3
Max horizontal boom extension	ft	10.4
Boom extension at max height	ft	1
Swinging Angle	°	155
<b>TANK CAPACITY</b>		
Hydraulic oil tank	gal	21.1
Diesel tank	gal	18.4
<b>CONNECTION FOR EQUIPMENT</b>		
FH		●
EURO		○

**NOTE:** All dimensions defined on model with wheels 12-16,5

● Standard    ○ Optional    - Not available



CONFIGURATION		CLASSIC 52
<b>TRANSMISSION</b>		
Hydrostatic		single gear
Speed	mph	18.6
<b>ENGINE TIER 4 FINAL</b>		
Builder		Yanmar
Power	kw/hp	51,7/69,3
Aftertreatment system		DOC + DPF
Drawbar pull	daN	3530
<b>HYDRAULIC</b>		
Pump type		gears pump
Hydraulic capacity	gal/psi	21.1/3,335
<b>TYRES</b>		
12-16,5		●
12,5-18		○
435/50 19.5		○
Turning radius	ft	10.7
<b>OTHER</b>		
Joystick		mechanical-electro proportional
Quick coupling		○
Electro-proportional double acting rear hydraulic connection		○
Front and rear LED lights		○
Rear trailer lights socket		○
6 t fixed tow hook		○
Engine water pre-heating		○
Air conditioning		○
Floating boom		○
Boom suspension		○
Manual 6-way diverter		○
PEB (Boom Electric Socket)		○
Creeper		○
Front constant flow		○
Bucket mode		●

