

2024-2025

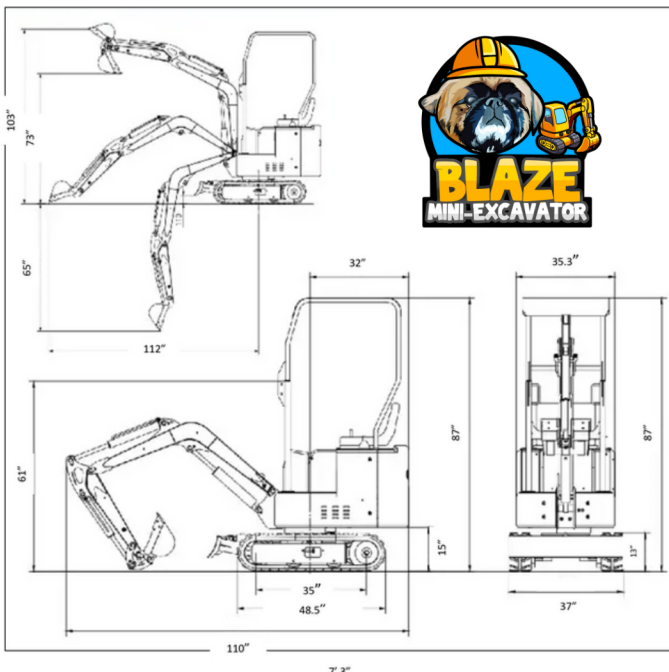

Ultra-Compact BLAZE Mini-Excavator

www.tristaraerial.com • 877-611-0380 • sales@tristaraerial.com

MODEL: BP6521H**Weight: 2205 lbs****Digging Bucket Capacity: 0.89 cu ft.****Bucket Width: 15"****Engine: BRIGGS & STRATTON****Bore Stroke: Single-Cylinder, Fan-Cooled****Rated Power: 11 hp @ 3600 rpm****Main Pump: Japan KDW5-6****Main Valve: Italy****Displacement: 6.8 ml/r****Swing Motor: Italy JKRS-230****Traveling Motor: Italy JKM-225****Travel Speed: 0.9 mph****MAIN DIMENSIONS****Overall (L x W x H): 110 in x 37 in x 87 in****Wheelbase: 36.6 in****Total Track Length: 48.5 in****Platform Ground Clearance: 15 in****Platform Back-turning Radius: 31 in****Chassis Width: 35.3 in****Track Height: 13 in****Track Width: 7 in****Operating Range****Max. Digging Depth: 65 in****Max. Vertical Digging Depth: 51 in****Max. Digging Height: 103 in****Max. Dumping Height: 73 in****Max. Digging Radius on Ground: 112 in****Min. Rotation Radius: 53 in****Max. Upgrade Height of Bulldozer Blade: 13.5 in****Max. Digging Depth of Bulldozer Blade: 10 in**www.tristaraerial.com

877-611-0380

Financing is available with approved credit.