

DT72



STANDARD FEATURES

- High Torque Drive system
- Extreme Gradeability - market leading
- Rear Oriented Boom position
- Auto Levelling Basket
- Maximum Approach Angle - market leading
- OSHA and ANSI 92.20 Standards certified
- High Pressure Water/Air connection to Basket
- Automatic Stabilization
- Negative Working Height - market leading
- Remote Management and Diagnostic software
- Up & Over - market leading
- Invisible Boom

ADDITIONAL/OPTIONAL FEATURES

Brushes for Boom protection	Custom Paint Options available (Upper and Lower sections)
Optional 1 Man Basket	Electro pump 110V
Optional Cages	Cage for materials handling
Optional Crane Hook	Extra Large Basket
16' Wire Control, control at ground	Fiberglass Basket
Radio Control	Hook & Crane certification
Auto-close Functionality	



TECHNICAL SPECIFICATIONS

MEASUREMENTS

A	Stowed Height with basket	7' 6"
B	Overall Length with basket	22' 11"
C	Overall Width with outrigger closed	6' 11"
D	Stowed Height without basket	7' 6"
E	Overall Length without basket	20' 11"
	Overall Width with outrigger open	7' 3"
	Length outrigger footprint	12'

Total weight 12694 lbs

PERFORMANCE

Platform working height (max)	71' 9"
Horizontal outreach (max)	29' 6"
Negative work	- 6' 7"
Up & over clearance	45' 11"
Basket Capacity	507 lbs
Hook Capacity	573 lbs
Basket rotation	180°
Turret rotation	720°
Maximum approach angle	23°
Longitudinal maximum gradient of the ground	7 %
Lateral maximum gradient of the ground	9 %
Standard power source	Diesel
Optional power source	Electro pump

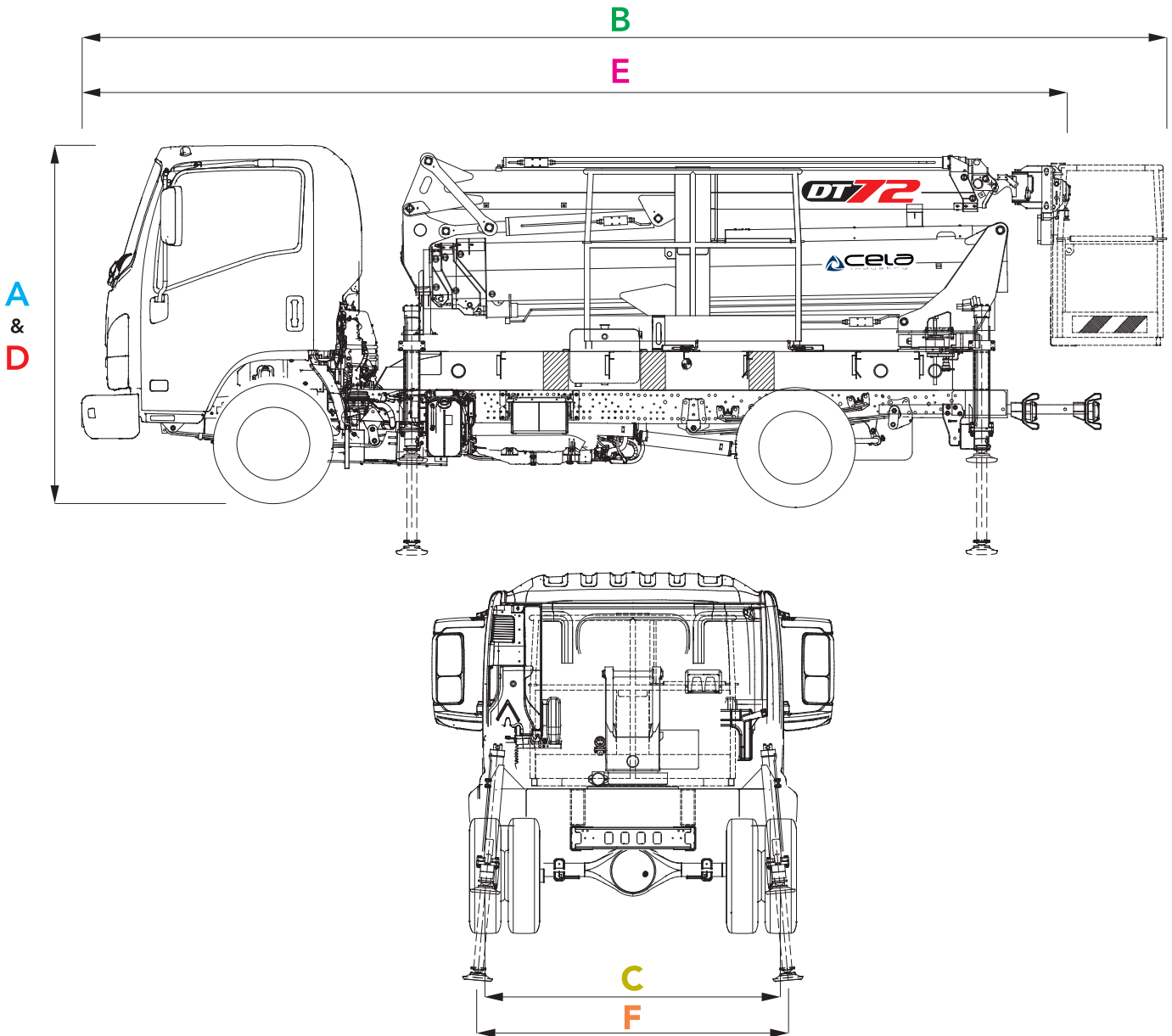

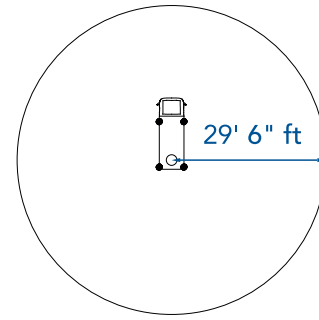
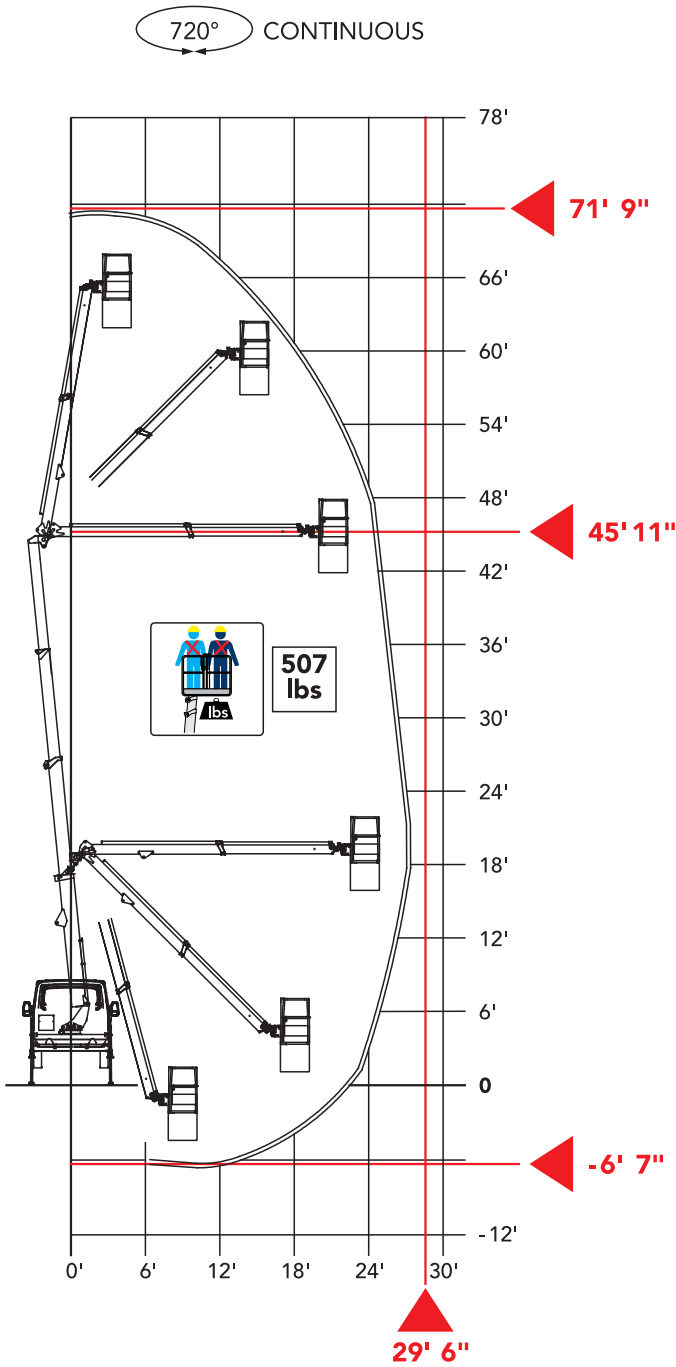

We fly all over

29' 6" ft →

45' 11" ft ↑

Authorized height landing

Multipurpose lifting options

2' 3" ft

4' 6" ft

5' 9" ft

Like an elevator

45' 11" ft

