

DT80

 **TRISTAR AERIAL**
LIFT & EQUIPMENT SALES, INC.



 **Cela**
Industry

STANDARD FEATURES

High Torque Drive system
 Extreme Gradeability - market leading
 Rear Oriented Boom position
 Auto Levelling Basket
 Maximum Approach Angle - market leading
 OSHA and ANSI 92.20 Standards certified
 High Pressure Water/Air connection to Basket
 Automatic Stabilization
 Negative Working Height - market leading
 Remote Management and Diagnostic software
 Up & Over - market leading
 Invisible Boom

ADDITIONAL/OPTIONAL FEATURES

Brushes for Boom protection	Custom Paint Options available (Upper and Lower sections)
Optional 1 Man Basket	Electro pump 110V
Optional Cages	Cage for materials handling
Optional Crane Hook	Extra Large Basket
16' Wire Control, control at ground	Fiberglass Basket
Radio Control	Hook & Crane certification
Auto-close Functionality	



TECHNICAL SPECIFICATIONS

MEASUREMENTS

A	Height Stowed with basket	7' 6"
B	Overall Length with basket	22' 11"
C	Overall Width with outrigger closed	6' 11"
D	Height Stowed without basket	7' 6"
E	Overall Length without basket	20' 11"
F	Overall Width with outrigger open	7' 3"
	Length outrigger footprint	12'

Total weight 12864 lbs

PERFORMANCE

Platform working height (max)	79' 5"
Horizontal outreach (max)	39' 4"
Negative work	- 16' 5"
Up & over clearance	45' 11"
Basket Capacity	507 lbs
Hook Capacity	573 lbs
Basket rotation	180°
Turret rotation	720°
Maximum approach angle	23 %
Longitudinal maximum gradient of the ground	7 %
Lateral maximum gradient of the ground	9 %
Standard power source	Diesel
Optional power source	Electro pump

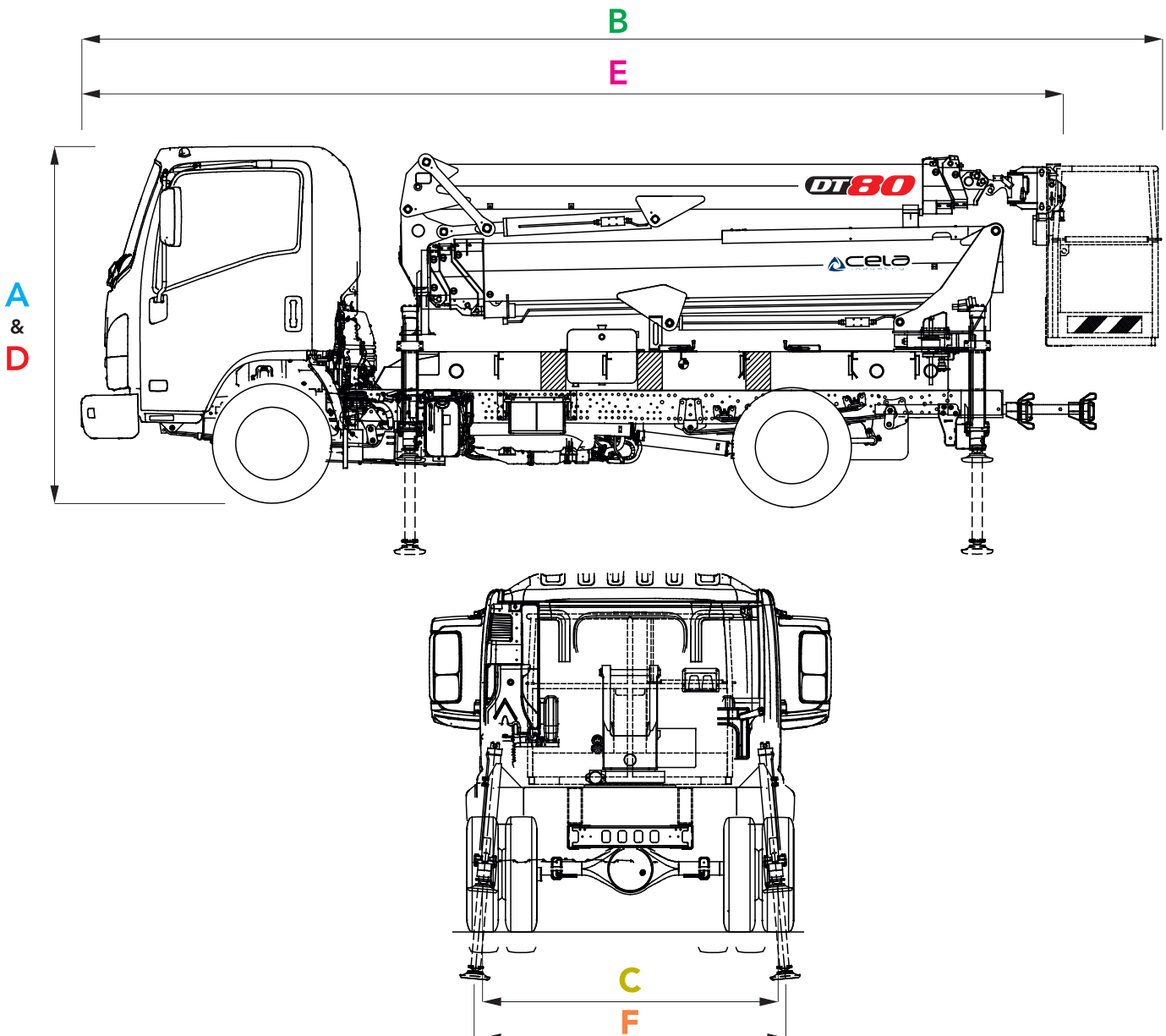

720° CONTINUOUS

