

ROUGH TERRAIN SCISSOR LIFTS

COMPACT 2668 / 3368 RT



OUTSTANDING ROUGH TERRAIN DRIVING FEATURES

- > 4 wheel drive
- > Automatic differential lock
- > Excellent gradeability of 40%
- > Ground clearance of 11 in

DURABLE AND EASY TO MAINTAIN

- > Outriggers positioned within the machine footprint
- > Durable and reliable upper control box
- > Optimized accessibility to components
- > Built-in diagnostic tool

EXCEPTIONAL PRODUCTIVITY

- > Fully proportional controls
- > Tight turning radius
- > One switch to deploy and retract all 4 outriggers



COMPACT 2668 / 3368 RT

ROUGH TERRAIN SCISSOR LIFTS

TECHNICAL DATA

	COMPACT 2668 RT	COMPACT 3368 RT
Working height	33 ft 2 in	39 ft
Platform height	27 ft 2 in	33 ft 0 in
Lift capacity	1,250 lb (3 pers.)	1,000 lb (3 pers.)
Lift capacity on the extension	330 lb	330 lb
A Length	10 ft 5 in	10 ft 5 in
B Width	5 ft 10 in	5 ft 10 in
C Height - stowed	8 ft	8 ft 5 in
D Wheelbase	6 ft 0 in	6 ft
E Ground clearance	11 in	11 in
Storage height	5 ft 3 in	5 ft 2 in
F Platform length	8 ft	8 ft
G Platform width	4 ft 9 in	4 ft 9 in
Extended platform length	12 ft 2 in	12 ft 2 in
Platform extension length	3 ft 11 in	3 ft 11 in
Number of extensions	1	1
Drive speed	0.4 - 3.4 mph	0.4 - 3.4 mph
Driveable at full height	26 ft 9 in	26 ft 9 in
Turning radius - outside	11 ft 6 in	11 ft 6 in
Lift / lower speed	35 s / 46 s	40 s / 51 s
Engine	Kubota, 18.5 kW (24.8 hp)	18.5 kW (24.8 hp)
Gradeability	40 %	40 %
Tilt alarm	3 °	3 °
Tires	26 x 12 - 16.5	26 x 12 - 16.5
Hydraulic tank capacity	20 gal	20 gal
Weight	7,787 lb	8,743 lb

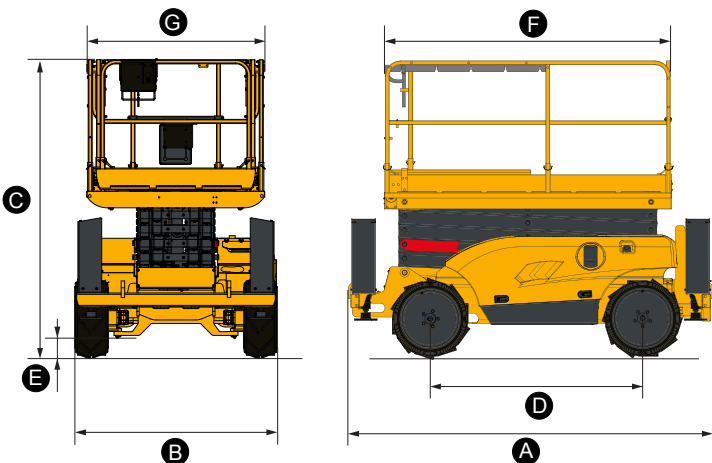

STANDARD EQUIPMENT

- > 4 wheel drive, 2 wheel steer
- > Brake release
- > Foam filled all terrain tires
- > 3 ft 9 in platform extension
- > Removable operator's control box
- > 5° tilt alarm
- > Hydraulic leveling jacks
- > Electronic horn
- > Hour meter
- > 12V - 74 Amph battery
- > Hydraulic brakes
- > Manual platform lowering
- > Lanyard attachment points
- > Towing hooks
- > Fold down guardrails

OPTIONS AND ACCESSORIES

- > Non-marking tires
- > Power to the platform
- > Swing-door gate
- > Hydraulic generator 3.5 kW
- > Biodegradable oil
- > Cold Weather Package
- > Telematics ready
- > Motion alarm (travel and elevate)
- > Travel alarm
- > Flashing beacon
- > 70 W platform workin light
- > Folding guardrails

