

## STAR 22 J / 26 J

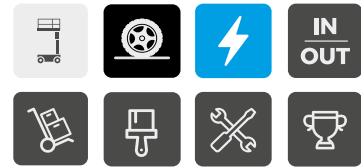

### OPTIMAL AGILITY IN CONFINED WORKING AREAS

- > Dynamic electric drive AC motors
- > Tight turning radius
- > Vertical jib allowing 9 ft 10 in outreach
- > Minimal maintenance and downtime
- > Maintenance free brushless AC motors
- > Haulotte Activ'Screen onboard diagnostic tool

### CENTRALIZED BATTERY FILLING

- > Longer lifetime
- > New ultra-rugged composite hoods
- > Increased durability on pins, bushings, non-painted parts, and fastening hardware
- > Smarter transport
- > Versatile and effective transport solutions with forklift pockets
- > 25% gradeability to easily climb truck ramps

# STAR 22 J / 26 J

## STANDARD EQUIPMENT

### VERTICAL MASTS

### TECHNICAL DATA

#### STAR 22 J STAR 26 J

Working height	28 ft 2 in	32 ft 1 in
Platform height	22 ft 2 in	26 ft 1 in
Horizontal outreach	9 ft 10 in	9 ft 10 in
Lift capacity	500 lb (2 pers.)	500 lb (2 pers.)
Lift capacity - outside	500 lb (2 pers.)	500 lb (1 pers.)
Platform size	2 ft 7 in x 3 ft 3 in	2 ft 7 in x 3 ft 3 in
<b>D</b> Length	8 ft 10 in	8 ft 10 in
<b>B</b> Width	3 ft 3 in	3 ft 3 in
Tailswing	0 in	0 in
<b>C</b> Wheelbase	3 ft 11 in	3 ft 11 in
<b>A</b> Height - stowed	6 ft 6 in	6 ft 6 in
<b>E</b> Ground clearance	4 in	4 in
Driveable at full height up to	22 ft 2 in	26 ft 1 in
Drive speed	0.4 - 3.1 mph	0.4 - 3.1 mph
Turning radius - outside	6 ft 2 in	6 ft 2 in
Turntable rotation	345°	345°
Vertical jib rotation	130° (+70°/-60°)	130° (+70°/-60°)
Tires	16x5x10.5	16x5x10.5
Tilt alarm	3°	3°
Gradeability	25 %	25 %
Hydraulic tank capacity	1.85 gal	2 gal
Batteries	24 V - 250 Ah	24 V - 250 Ah
Weight	6,260 lb	6,400 lb

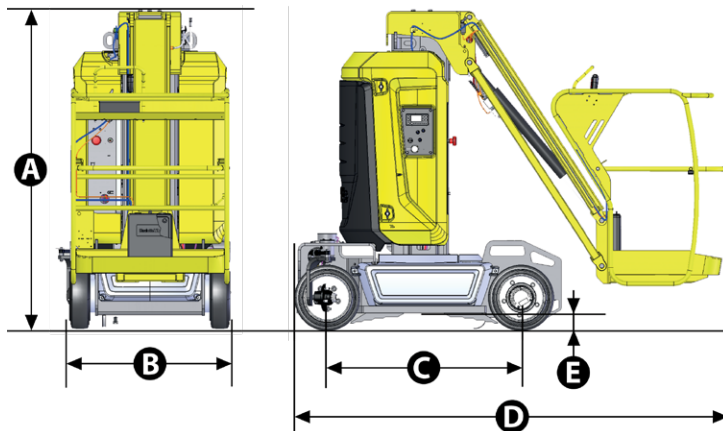

- > 24 V electric drive brushless AC motors
- > 24 V - 250 Ah traction batteries
- > 35A battery charger
- > Battery charge indicator
- > Haulotte Activ'Screen on-board diagnostic tool
- > Centralized battery filling
- > Forklift pockets
- > Towing hooks and lifting eyes
- > Pothole protection
- > 2 Front drive wheels
- > 2 Rear steering wheels
- > Non-marking tires
- > Brake release
- > Hourmeter
- > Horn
- > Emergency stop buttons at platform and ground level
- > Load controller in the platform
- > Emergency hand pump
- > 2 control stations - platform and ground level
- > 2 Lanyard attachment points
- > Travel alarm

## OPTIONS AND ACCESSORIES

- > Haulotte Activ'Shield Bar
- > AC Power to the platform (Standard on US machines)
- > Air line to the platform
- > Swing door entry gate (Standard on US machines)
- > Biodegradable oil
- > Maintenance-free batteries
- > Telematics ready
- > Hydraulic oil for cold climates
- > Flashing light
- > Working light

