

# CRAWLER EXCAVATOR

# ZE35GU



**ZOOMLION**





# CRAWLER EXCAVATOR ZE35GU

	Items	ZE35GU	
Basic Technical Data	Operating Weight	3790 kg	8,355 lb
	Standard bucket capacity	0.1 m <sup>3</sup>	0.13 yd <sup>3</sup>
	Slewing Speed	9 r/min	
	Traveling Speed (high/low)	4.5/2.3 km/h	2.8/1.4 mph
	Digging Force of Bucket	34.6 kN	7,775 lbf
	Digging Force of Stick	19.5 kN	4,380 lbf
Engine	Engine Manufacturer	Kubota	
	Engine Model	D1703	
	Rated Power	18.5 kW /2200 rpm	25.1 HP /2200 rpm
	Displacement	1.647 L	100.5 in <sup>3</sup>
	Emission Standard	EU Stage V/Tier 4F	
Dimensions	Length	4915 mm	193.65 in
	Width	1700 mm	66.98 in
	Height	2530 mm	99.68 in
	Tail Slewing Radius	850 mm	33.49 in
	Track Gauge	1400 mm	55.16 in
	Length of Track on Ground	1640 mm	64.61 in
Operating Range	Max. Digging Radius	5525 mm	217.68 in
	Max. Digging Reach at Ground Level	5407 mm	219 in
	Max. Digging Depth	3003 mm	118.31 in
	Max. Digging Height	4859 mm	191.44 in
	Max. Dumping Height	3438 mm	135.45 in

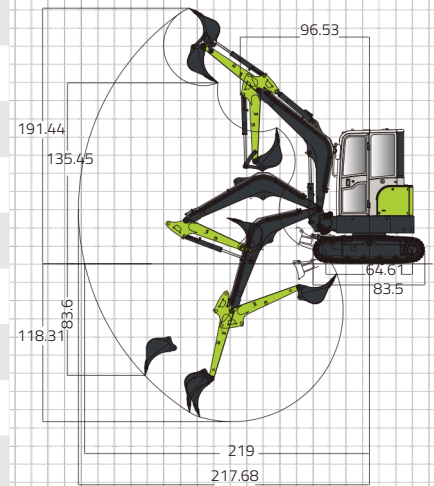
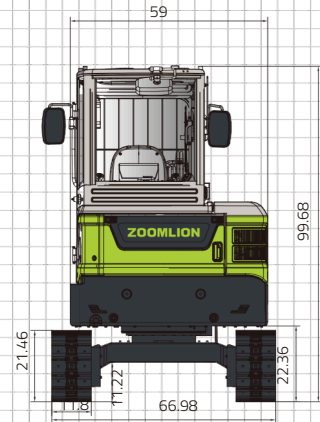
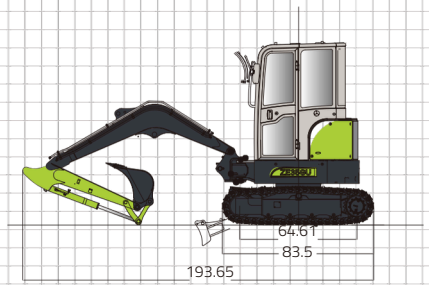

219 E. Madison St. Dublin, GA 31021  
sales@tristaraerial.com (877) 611-0380

**ZOOMLION**

**Zoomlion Heavy Industry Science & Technology Co.,Ltd.**

Add: No.361, South Yinpen Road, Changsha, Hunan Province, P.R.China 410013

Email: earthmoving@zoomlion.com

Copyright©2023 Zoomlion. All rights reserved. Reproduction and copying of any part of contents is not allowed for any purposes without Zoomlion's approval.  
Note: Materials and specifications are subject to change without notice. Featured machines in photos may include additional equipment.

